

**Operation and Installation Manual** .....



**XL 300.1**

**CERWIN-VEGA!  
MOBILE AUDIO**

**POWER AMPLIFIER**

**CERWIN-VEGA!**  
MOBILE AUDIO

**CERWIN-VEGA! XL300.1 POWER SYSTEM AMPLIFIERS**

## INTRODUCTION

*Thank you for purchasing a Cerwin-Vega! car audio amplifier. This power amplifier has been designed to provide high quality performance with a minimum of maintenance. However, it's performance will only be as good as the care and quality of components with which it is installed. We therefore advise that you read these instructions very carefully to familiarize yourself with the product and it's features.*

Before installing the power amplifier please read this instruction manual carefully. The instructions for mounting and connecting the unit have to be followed precisely. If necessary, a service center should be consulted.

All connections for DC power, signal input and speaker outputs can be carried out easily and safely by way of RCA, screw terminals and plug-in connectors.

## INSTALLATION INSTRUCTIONS

This section lists Mounting and Wiring Precautions for installing Cerwin-Vega! XL Series amplifiers. Combined with the experience of a professional installer, these safeguards provide enough detail to successfully complete an installation. If you do not have the necessary skills, do not install the amplifier yourself. Instead, see your authorized Cerwin-Vega! dealer for installation recommendations.

2. Mount the amplifier on a rigid surface. Avoid mounting to subwoofer enclosures or areas prone to vibration. Do not install the amplifier on plastic or other combustible materials.
3. Prior to drilling, make sure proposed mounting holes will not cut into the fuel tank, fuel lines, brake lines (under chassis) or electrical wiring.

## MOUNTING PRECAUTIONS

Although Cerwin-Vega! XL Series amplifiers incorporate heat sinks and protection circuits, mounting the amplifier in a tight space without any air movement can still damage internal circuitry over time. Choose a site that provides adequate ventilation around the amplifier. For easy system set-up, mount the amplifier so the front panel controls will be accessible after installation. In addition, observe the following precautions:

1. For the most efficient cooling, mount the amplifier so cool air runs along the length of the fins rather than across them. Remember, any moving air will dissipate heat.

## WIRING PRECAUTIONS

Read all wiring precautions. If you are not sure of the connections, contact your authorized Cerwin-Vega! dealer.

1. Before installation, make sure the source unit Power switch is in the OFF position.
2. Disconnect the negative (-) lead of the battery before making any power connections.
3. When making connections, be sure that each connection is clean and secure. Insulate final connections with electrical

**OPERATION AND INSTALLATION MANUAL**

tape or shrink tubing. Failure to do so may damage your equipment.

4. A secure clean ground connection is critical to the performance of your Cerwin-Vega! amplifier. Use the shortest ground wire possible and securely connect to the car chassis to minimize resistance and avoid noise problems.
5. Add an external fuse on the amplifier's positive (+) power lead and connect it as close as possible to the vehicle's (+) battery

terminal. Use a rating that equals the total current consumption at full output of all amplifiers in the system. This external fuse will protect the vehicle from short circuits that can cause a fire.



**XL 300.1 FEATURES**

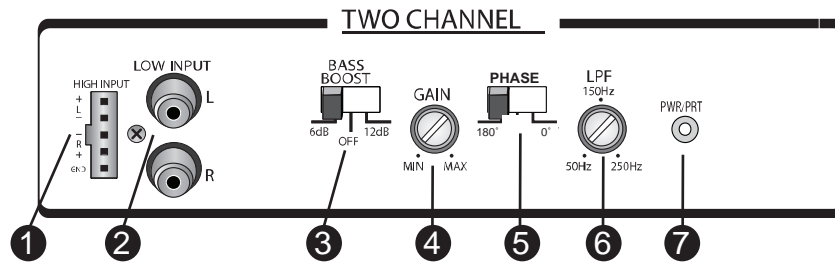

- High level input (1)
- Low level input (2)
- Bass boost switch (3)
- Gain (input level) controls (4)
- Phase Switch (5)
- Low pass filter control (6)
- Power protection (7)
- Remote turn-on\*
- Short circuit protection (7)

**CERWIN-VEGA! XL300.1 POWER SYSTEM AMPLIFIERS****PRECAUTIONS**

- This unit is designed for negative ground 12V DC operation only.
- Total system impedance must not be less than 2 ohms.
- Avoid installing the unit where:
  - *It would be subject to high temperatures, such as from direct sunlight or hot air from the heater.*
  - *It would be exposed to rain or moisture.*
  - *It would be subject to dust or dirt.*
- Do not cover the unit with carpet or wires.
- This power amplifier employs a protection circuit to protect the transistors and speakers if the amplifier malfunctions. Do not attempt to test the protection circuits by covering the heatsink or connecting improper loads.
- Do not use the unit with a weak auto battery as

its optimum performance depends on a normal battery supply voltage.

- For safety reasons, keep the volume of your car audio system moderate so that you can still hear normal traffic sounds outside your car.

**FUSE REPLACEMENT**

If the fuse blows, check the power connection and replace the fuse. If the fuse blows again after replacement, there may be an internal malfunction. In this case, consult your dealer.

**Warning**

Use the specified amperage fuse. Use of a higher amperage fuse may cause serious damage to the amplifier.

**Protection Circuit**

This amplifier is provided with a protection circuit which operates when:

- *the unit is overheated or when the speaker terminals are short circuited.*

## OPERATION AND INSTALLATION MANUAL

## WIRING INSTRUCTIONS

### POWER CONNECTION

- The battery terminal (BATT) must be connected to the positive terminal of the vehicle battery (with system fuse inline) to provide an adequate voltage source and minimize noise. Connecting the battery terminal lead to any other point will reduce the power output and may cause noise and distortion. Use only #10 gauge or thicker (smaller gauge #) wire for this lead and connect it to the terminal of the battery (with system fuse inline) after all other wiring is completed. This connection must be fused at the battery terminal.

### GROUND CONNECTION

- The ground terminal (GND) connection is also critical to the correct operation of the amplifier. Use a wire of the same gauge as the power connection (#12 or thicker) and connect it between the ground terminal (GND) of the amplifier and a metal part of the vehicle close to the mounting location. This wire should be as short as possible and any paint or rust at the grounding point should be scraped away to provide a clean metal surface to which the end of the ground wire can be screwed or bolted.

### REMOTE TURN-ON CONNECTION

- The amplifier is turned on by applying +12V to the remote turn-on terminal (REM). The wire lead to this terminal should be connected to the "remote" lead from the car stereo which will provide the +12V only when the car stereo is turned on. If the car stereo does not provide an "remote" lead, the remote turn-on lead may be wired to an "Accessory", "Radio" or "Power Antenna" terminal in the car's fuse block. This will turn the amplifier on and off with the ignition key, regardless of whether the

car stereo is on or off. The remote turn-on lead does not carry large currents. So #20 gauge wire may be used for this application.

### SPEAKER CONNECTIONS

- Depending on the type and number of speakers used with the amplifier wire them to the speaker terminals as per the appropriate wiring diagram. For most applications #18 gauge wire should be used for the speaker leads but in no case thinner than #20 gauge. For leads in excess of 10 feet #16 gauge is recommended. When wiring the speakers, pay careful attention to the polarity of the terminals on the speakers and make certain they correspond to the polarity of the corresponding terminals on the amplifier. Do not ground any speaker leads to the chassis of the vehicle. Please see your authorized Cerwin-Vega! dealer for specific wire recommendations.

### INPUT CONNECTIONS

- This amplifier features both high and low-level input capability. Use either the low-level or high-level inputs, not both.
- If the car stereo does not provide low-level outputs, the amplifier may be connected via the speaker (high-level), outputs from the stereo. Wire the speaker leads from the car stereo to the 5-pin adapter harness as shown in the diagram (shielded cables is not required for this application) and plug the connector into the mating high level input connector on the amplifier. Carefully splice and insulate all wire connections.

**CAUTION:** Use either the low-level or the high-level inputs on the amplifier. Do not use both input levels at the same time.

CERWIN-VEGA! XL300.1 POWER SYSTEM AMPLIFIERS

## INPUT WIRING DIAGRAM

### USING THE HIGH LEVEL INPUT

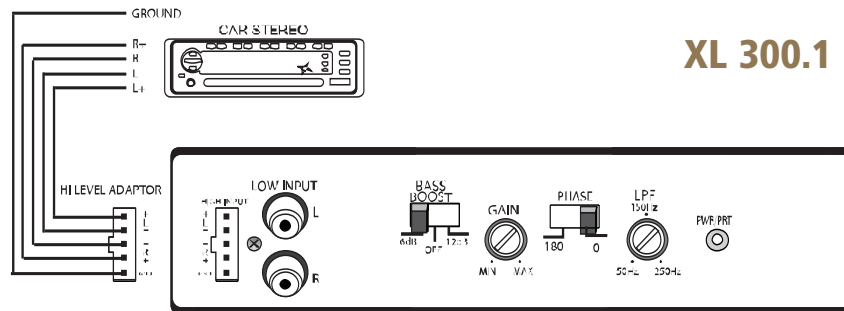

OPERATION AND INSTALLATION MANUAL

## SPEAKER CONNECTIONS

MINIMUM IMPEDANCE = 2 OHMS

**XL 300.1**

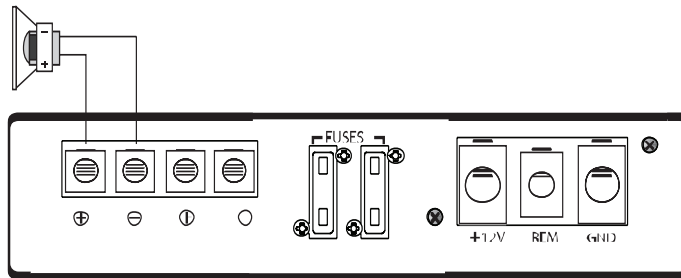

### DUAL DRIVERS

EACH DRIVER MINIMUM IMPEDANCE = 4 OHMS

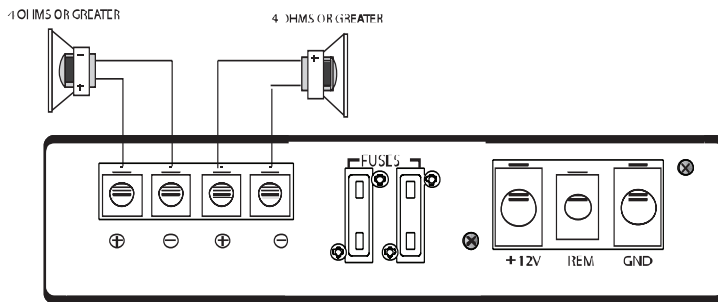

### DUAL VOICE COIL SUBS

EACH VOICE COIL MUST BE 4 OHMS OR GREATER!

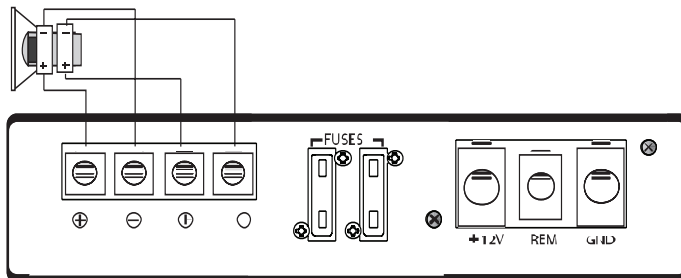

## CERWIN-VEGA! XL300.1 POWER SYSTEM AMPLIFIERS

## POWER CONNECTION LEADS

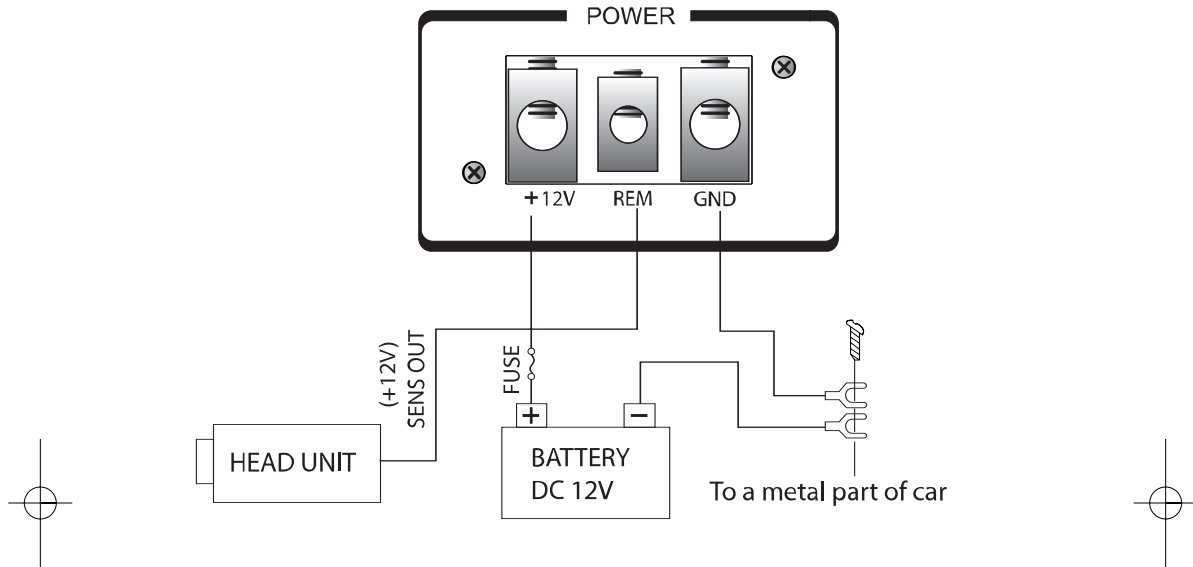

## NOTES ON THE POWER SUPPLY

- Connect the +12V power input lead only after all other leads have been connected.
- Be sure to connect the ground wire of the unit securely to a metal part of the car. A loose connection may cause a malfunction of the amplifier.
- REM: The unit is turned on by applying +12 Volts to this terminal. This terminal does not draw heavy current like the Power Terminals so a thinner connecting wire is acceptable. Standard 20 GAUGE is fine and the standard color is yellow.
- Use the power supply lead with a fuse attached whose value is the same as original fuse.
- **Place the fuse in the power supply lead as close as possible to the car battery.**
- During full power operation, Maximum current will run through the system. Therefore, make sure that the leads to be connected to the +12V and GND terminals of the unit respectively must be larger than 10-Gauge (AWG.10) or larger.

## OPERATION AND INSTALLATION MANUAL

## OPERATION

After the amplifier has been installed and all connections have been secured, turn the radio on so that the amplifier is switched on automatically. After a short power-on period, the amplifier reaches its full performance.

Now turn up the volume slowly using the volume control of the radio. If there is no sound or only distortion, switch off the radio immediately. The amplifier will also switch off automatically. Check if all connections have been made correctly.

- **POWER = LED POWER INDICATOR**

After the orderly connection of the three power terminals, the LED indicator shines green and goes out with off.

- **PROTECT = LED PROTECTION INDICATOR**

This unit is equipped with an overload protection. Immediately upon overloading (due to short circuit or extreme temperature) the

overload protection is activated, and the red LED indicator is illuminated. The amplifier is now protected against damage. In case of thermal protection a short cooling time must be allowed after which the amplifier automatically resumes operation.

- **GAIN = INPUT LEVEL CONTROL**

The input level control allows the system to work well with a wide range of input levels. As a guideline the following procedure is recommended: If you use several amplifiers, the adjustment has to be made for each set separately tune in the volume of your car radio to 2/3 of the maximum volume. Now turn the gain control of the amplifier from "Min" to "Max" direction until you can hear distortions. Then turn the level control a little back to "Min". The gain control adjustment is finished now.

---

## HOW TO PROCEED IN CASE OF FAULTS

- **NO FUNCTION:**

Check that all the fuses are good. If so check to be sure that the head unit is turning on. Check to be sure that all the power, Signal and speaker connections are tight.

- **NO SOUND:**

Speaker connections are not correct. Check the RCA cables.

- **NO SOUND / RED LED PROTECTION ILLUMINATES:**

Check that the speaker leads are not touching each other or the car chassis. Be sure the minimum speaker is not too low for the configuration.

- **POOR SOUND QUALITY (DISTORTIONS):**

Check the amplifier GAIN setting. Check the RCA grounds. Check that the speaker wires are not touching the car chassis. Check that the car battery is properly charged

- **NO STEREO SOUND AND A WEAK BASS:**

One or more speaker connections ( (+) and (-) are reversed) are wired out of phase.

## CERWIN-VEGA! XL300.1 POWER SYSTEM AMPLIFIERS

### INTERFERENCE

All cables are sources of interference. The power cable and RCA audio cable are very prone to interference; the remote cables are less prone. There is often interference caused by the generator (piping), ignition (cracking) or other car electronic parts. Most of these problems can be eliminated with correct and careful cable installation. These are the following guidelines:

- Use only a quality audio cable for the wiring between "low level in" of the amplifier and RCA or DIN output of the radio.
- Lay the signal, speaker and power cables separately with enough distance from another and also from each other car cable. If not possible, you can lay the circuit and ground cable together with the signal cables. Audio and speaker cable should be as far away from these as possible. The REM cable to the automatic antenna output of the radio can be laid together with the signal cables.
- Avoid ground loops by laying the ground wiring of all components to a center point. You can find the best central point in measuring the voltage directly at the battery and comparing

this voltage value with the chosen ground point and the (+) terminal of the amplifier. With the amplifier playing, if there is little or no voltage difference at the amplifier input from the battery, then you have found a good location. You should measure with the ignition being switched on as well as the (rear window heating and light).

- If there are pickups from external electrical sources into the speaker cables, divide the core leads and twist them together.
- If there are noises from the car electronics, add an interference suppression choke into the power wiring.
- If there are humming noises, use thicker ground cables or add further ground cables to the chassis.
- To reduce contact resistance and loose contacts, please tie the cable ends or use multi core cable ends, spade terminals or others.
- In the event that these steps are unsuccessful, the use of a ground loop isolator may solve the problem.

### PRODUCT SPECS

	<b>XL300.1</b>
<b>Frequency Response</b>	15Hz - 250Hz, +0db -3 dB
<b>Signal Noise Ratio, 4 ohm ref.</b>	>85 dB
<b>THD, 4 ohm, - typical</b>	0.05%
<b>Input Sensitivity Low Level</b>	250mV ~ >4.0V
<b>4 Ohm Power output</b>	270W @ 1% THD typical
<b>2 Ohm Power output</b>	380W @ 1% THD typical
<b>Dimensions</b>	2.25" H X 10.5" W X 13.25" L



**OPERATION AND INSTALLATION MANUAL**

**NOTES:**

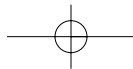
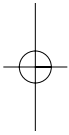



 **CERWIN-VEGA!**  
MOBILE AUDIO

9340 De Soto Ave., Chatsworth, CA 91311  
Phone: 1-818-534-1500 • Fax: 1-818-534-1590 • Email: [info@cerwin-vega.com](mailto:info@cerwin-vega.com)