

Cerwin-Vega

mobile

The logo for Cerwin-Vega, featuring the brand name in a stylized, outlined, blocky font.

SUBWOOFER OWNERS MANUAL

Dear Cerwin-Vega Mobile Customer,

Thank you for making Cerwin-Vega Mobile your choice for high performance car audio products. At Cerwin-Vega Mobile our goal is to produce products of unsurpassed quality. We believe you will not find a better value anywhere in the mobile audio environment.

To ensure that your new Cerwin-Vega Mobile speakers provide years of enjoyment you should consider having them installed by a professionally trained technician. They have the knowledge to make your new speakers perform their very best.

Prolonged exposure to sound pressure levels in excess of 100dB can cause permanent hearing loss. Cerwin-Vega Mobile speakers can exceed that level, so please exercise restraint when listening and enjoy your new speakers for years to come.

The Cerwin-Vega Mobile Team



SERIES WOOFER FEATURES

Mica filled polypropylene cone

Red rubber surround

Woven tinsel leads

Bumped back plate with vented pole piece

Dual 2" voice coil

2 or 4 ohm

PHYSICAL DIMENSIONS

Dimension (in./mm)	VEGA 10.2/10.4	VEGA 12.2/12.4
Total Diameter (A)	10.4 in. (264 mm)	12.24 in. (311 mm)
Mounting Diameter (B)	9.25 in. (235 mm)	11 in. (280 mm)
Screw Hole Diameter (C)	9.6 in. (244 mm)	11.7 in. (297 mm)
Mounting Depth (D)	5.75 in. (146 mm)	6.5 in. (166 mm)
Magnet Diameter (E)	6.0 in. (153 mm)	6.0 in. (153 mm)
Displacement	0.059 ft ³ / 1.7 liter	0.094 ft ³ / 2.7 liter

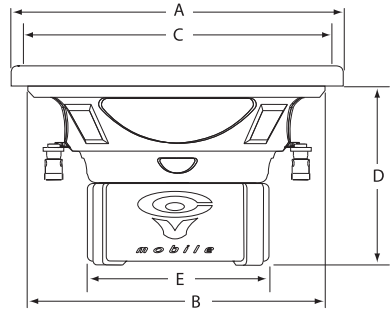
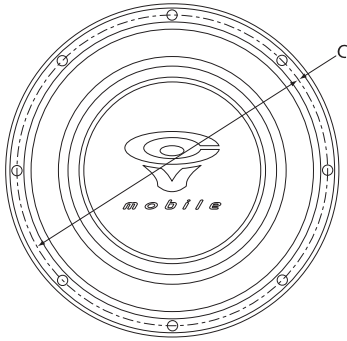

THIELE/SMALL PARAMETERS

Parameter (unit)	VEGA 10.2	VEGA 10.4	VEGA 12.2	VEGA 12.4
SPL (dB)	84.3	84.5	86.1	85.6
Re (Ω) [series]	3.80	6.60	3.60	6.80
Qms	4.767	4.775	4.801	4.580
Qes	0.558	0.669	0.602	0.706
Qts	0.499	0.587	0.535	0.612
Fs (Hz)	33.948	35.270	29.139	30.273
Vas (L)	24.712	27.838	65.101	60.313
Cms (mm/N)	194.236	179.952	175.771	162.843
Mms (g)	159.747	113.154	169.730	169.731
Sd (m ²)	33.006	33.006	51.071	51.071
BL (T*M)	7.071	7.865	6.816	8.817
Xmax (mm) one way	6.5	6.5	7.0	7.0
Pwr (W) NOM/MAX	200/400	200/400	200/400	200/400

ENCLOSURE

The enclosures specified below are offered as a suggestion only. Assistance from an authorized Cerwin-Vega Mobile retailer is recommended for designing the correct system for your vehicle. All volumes below are shown as gross internal volumes, driver and vent displacement has been accounted for. The use of a 30Hz sub-sonic filter is recommended on most vented enclosures.

Sealed	VEGA 10.2/10.4	VEGA 12.2/12.4
Vb (ft ³)	0.7	1.0
F3 (Hz)/QTC	54/0.65	41/0.88
Power Handling (Watts RMS)	200	200
Vented		
Vb (ft ³)	1.0	1.75
Fb/F3 (Hz)	45/38	41/33
Port (in.) [dia. x length]	3 x 7.15	4 x 8.5
Power Handling (Watts RMS)	200	200

Warranty

Cerwin-Vega Mobile warrants all amplifiers and speakers to be free of defects in material or workmanship for a period of 1 year.

Warranty Procedure:

Cerwin-Vega Mobile strongly suggests all warranty claims should be handled through an authorized dealer. Because of the technical nature of our products, performance problems can often be the result of improper usage or installation. An authorized retailer can help determine if this is the case and will save you the time of returning an item that is not actually defective.

For all VEGA subwoofer models the cone is to be removed from the basket as completely as possible. Cut the surround and then the spider. After this, the cone should lift out.

For VEGA coaxial models, the tweeter needs to be broken off and sent in with the cone.

All returns must have the serial number taped to the cone. The serial number can be found on the basket on all speakers and underneath the spider attached to the top of the magnet plate.

Please remove the sticker and tape it to the cone. This process will save everyone on shipping costs and allow us to check and replace speakers much faster.

For all V-MAX models as well as all amplifier models, the defective unit needs to be returned. For speaker systems such as Vmax component models only return the defective part (i.e midbass, tweeter or crossover).

Shipping:

Once you have your RA number, ship your return to:

Cerwin-Vega Mobile
ATTN: Customer Service Dept.
6915 W. Frye Road
Chandler, AZ 85226

When we receive your return, we will process your order. Please make sure that you clearly mark the RA number on the outside of the box and on the shipping label.

If the RA number is not on the outside of box/label, it will be returned to sender!

Specifications subject to change without notice.



mobile

6915 W. Frye Road
Chandler, AZ 85226
480 838 9422 • 480 491 1201 [fax]
www.cerwinvegamobile.com